

STANDARDS FOR INTERCONNECTION OF DISTRIBUTED GENERATION

Exhibit G - Interconnection Service Agreement

1. Parties. This Interconnection Service Agreement (“Agreement”), dated as of **12-18-2018** is entered into, by and between **NSTAR Electric d/b/a Eversource Energy**, a Massachusetts corporation with a principal place of business at **247 Station Drive, Westwood, MA 02090** (hereinafter referred to as the “Company”), and **BE RE, LLC** a corporation with a principal place of business at **50 W. Broadway, Salt Lake City, Utah 84109** (“Interconnecting Customer”). (The Company and Interconnecting Customer are collectively referred to as the “Parties”). Terms used herein without definition shall have the meanings set forth in Section 1.2 of the Interconnection Tariff which is hereby incorporated by reference. **WO# 2273508 (2000 kW AC)**.
2. Basic Understandings. This Agreement provides for parallel operation of an Interconnecting Customer’s Facility with the Company EPS to be installed and operated by the Interconnecting Customer at **239 Flag Swamp Rd, Dartmouth, MA 02747 Acct# TBD**. A description of the Facility is located in Attachment 1. If the Interconnecting Customer is not the Customer, an Agreement between the Company and the Company’s Retail Customer, attached as Exhibit H to the Interconnection Tariff, must be signed and included as an Attachment to this Agreement. If neither the Interconnecting Customer nor the Customer is the Landowner of the property where the Facility is sited, a Landowner Consent Agreement, attached as Exhibit I to the Interconnection Tariff, must be signed and included as an Attachment to this Agreement, unless the Company, in its sole discretion, waives this requirement.

The Interconnecting Customer has the right to operate its Facility in parallel with the Company EPS immediately upon successful completion of the protective relays testing as witnessed by the Company and receipt of written notice from the Company that interconnection with the Company EPS is authorized (“Authorization Date”).

3. Term. This Agreement shall become effective as of the Effective Date. The Agreement shall continue in full force and effect until terminated pursuant to Section 4 of this Agreement.
4. Termination.
 - 4.1. This Agreement may be terminated under the following conditions.
 - 4.1 a) The Parties agree in writing to terminate the Agreement.
 - 4.1 b) The Interconnecting Customer may terminate this agreement at any time by providing sixty (60) days written notice to Company.

STANDARDS FOR INTERCONNECTION OF DISTRIBUTED GENERATION

- 4.1 c) The Company may terminate this Agreement upon the occurrence of an Event of Default by the Interconnecting Customer as provided in Section 18 of this Agreement.
- 4.1 d) The Company may terminate this Agreement if the Interconnecting Customer either: (1) fails to energize the Facility within 12 months of the Authorization Date; or, (2) permanently abandons the Facility. Failure to operate the Facility for any consecutive 12 month period after the Authorization Date shall constitute permanent abandonment unless otherwise agreed to in writing between the Parties.
- 4.1 e) The Company, upon 30 days notice, may terminate this Agreement if there are any changes in Department regulations or state law that have a material adverse effect on the Company's ability to perform its obligations under the terms of this Agreement.
- 4.2. Survival of Obligations. The termination of this Agreement shall not relieve either Party of its liabilities and obligations, owed or continuing at the time of termination. Sections 5, 10, 12, 13, and 25 as it relates to disputes pending or for wrongful termination of this Agreement shall survive the termination of this Agreement.
- 4.3. Related Agreements. Any agreement attached to and incorporated into this Agreement shall terminate concurrently with this Agreement unless the Parties have agreed otherwise in writing. If the Interconnection Service Agreement is signed prior to a Detailed Study (if applicable), the System Modifications construction schedule from the Detailed Study when finalized shall be deemed a part of the signed Interconnection Service Agreement.
5. General Payment Terms. The Interconnecting Customer shall be responsible for the System Modification costs and payment terms identified in Attachment 3 of this Agreement and any approved cost increases pursuant to the terms of the Interconnection Tariff. Interconnecting Customers shall not be required to pay any costs related to Company infrastructure upgrades or System Modifications upon execution of the Interconnection Service Agreement (or once the Interconnecting Customer receives the construction schedule). Interconnecting Customers shall have 120 Business Days from the date of execution of an Interconnection Service Agreement to pay 25 percent of those costs; if an Interconnecting Customer pays such cost within the 120 Business Day Time Frame, the Interconnecting Customer shall have an additional 120 Business Days from the date of first payment to pay the remainder of the costs. If the system modifications exceed \$25,000, the Interconnecting Customer is eligible for a payment plan, including a payment and construction schedule with milestones for both parties, and any such payment plan shall be set forth in Attachment 3. The payment plan may include

STANDARDS FOR INTERCONNECTION OF DISTRIBUTED GENERATION

a payment schedule different than the 120 Business Day payment schedule requirements set forth in this paragraph above.

Construction estimates are valid for 60 Business Days from when they are delivered to the Interconnecting Customer. If an Interconnecting Customer payment is not received within 60 Business Days of receiving the Interconnection Service Agreement in the Expedited Process, or the Impact Study in the Standard Process, the Company has the right to reassess construction costs and Time Frames. In the event that the Interconnecting Customer fails to pay the Company within the Time Frame required by this provision, the Company will require the Interconnecting Customer to reapply for interconnection. Further, any fees paid will not be refunded. The construction schedule will commence once the Interconnecting Customer's financial payment has been made in full or as otherwise provided in Attachment 3. The Company's obligation to the construction schedule (as it appears in either the Interconnection Service Agreement or the Detailed Study, if the Interconnecting Customer has opted to sign the Interconnection Service Agreement without a Detailed Study) begins on the next Business Day after the Company receives full payment for such construction or as otherwise provided in Attachment 3.

5.1. Cost or Fee Adjustment Procedures.

The Company will, in writing, advise the Interconnecting Customer in advance of any cost increase for work to be performed up to a total amount of increase of 10% only. Interconnecting Customers who elected to execute an Interconnection Services Agreement following the completion of the Impact Study but prior to the commencement of any required Detailed Study, pursuant to Section 3.4(g) of the Interconnection Tariff, shall be responsible for any System Modifications costs, $\pm 25\%$, as identified by the Company in the Impact Study. All costs that exceed the above caps will be borne solely by the Company. Any such changes to the Company's costs for the work shall be subject to the Interconnecting Customer's consent. The Interconnecting Customer shall, within thirty (30) Business Days of the Company's notice of increase, authorize such increase and make payment in the amount up to the above caps, or the Company will suspend the work and the corresponding agreement will terminate.

5.2. Final Accounting.

An Interconnecting Customer may request a final accounting report of any difference between (a) Interconnecting Customer's cost responsibility under this Agreement for the actual cost of the

STANDARDS FOR INTERCONNECTION OF DISTRIBUTED GENERATION

System Modifications, and (b) Interconnecting Customer's previous aggregate payments to the

Company under the Interconnection Service Agreement for such System Modifications within 120

Business days after completion of the construction and installation of the System Modifications described in an attached exhibit to the Interconnection Service Agreement. Upon receipt of such a request from an Interconnecting Customer, the Company shall have 120 Business days to provide the requested final accounting report to the Interconnecting Customer. To the extent that Interconnecting Customer's cost responsibility in the Interconnection Service Agreement exceeds Interconnecting Customer's previous aggregate payments, the Company shall invoice Interconnecting Customer and Interconnecting Customer shall make payment to the Company within 45 Business Days. To the extent that Interconnecting Customer's previous aggregate payments exceed Interconnecting Customer's cost responsibility under this agreement, the Company shall refund to Interconnecting Customer an amount equal to the difference within forty five (45) Business Days of the provision of such final accounting report.

6. Operating Requirements.

6.1. General Operating Requirements.

Interconnecting Customer shall operate and maintain the Facility in accordance with the applicable manufacturer's recommended maintenance schedule, in compliance with all aspects of the Company's Interconnection Tariff. The Interconnecting Customer will continue to comply with all applicable laws and requirements after interconnection has occurred. In the event the Company has reason to believe that the Interconnecting Customer's installation may be the source of problems on the Company EPS, the Company has the right to install monitoring equipment at a mutually agreed upon location to determine the source of the problems. If the Facility is determined to be the source of the problems, the Company may require disconnection as outlined in Section 7.0 of this Interconnection Tariff. The cost of this testing will be borne by the Company unless the Company demonstrates that the problem or problems are caused by the Facility or if the test was performed at the request of the Interconnecting Customer.

6.2. No Adverse Effects; Non-interference.

Company shall notify Interconnecting Customer if there is evidence that the operation of the Facility could cause disruption or deterioration of service to other Customers served from the same Company EPS or if operation of the Facility could cause damage to

STANDARDS FOR INTERCONNECTION OF DISTRIBUTED GENERATION

Company EPS or Affected Systems. The deterioration of service could be, but is not limited to, harmonic injection in excess of IEEE Standard 1547-2003, as well as voltage fluctuations caused by large step changes in loading at the Facility. Each Party will notify the other of any emergency or hazardous condition or occurrence with its equipment or facilities which could affect safe operation of the other Party's equipment or facilities. Each Party shall use reasonable efforts to provide the other Party with advance notice of such conditions.

The Company will operate the EPS in such a manner so as to not unreasonably interfere with the operation of the Facility. The Interconnecting Customer will protect itself from normal disturbances propagating through the Company EPS, and such normal disturbances shall not constitute unreasonable interference unless the Company has deviated from Good Utility Practice. Examples of such disturbances could be, but are not limited to, single-phasing events, voltage sags from remote faults on the Company EPS, and outages on the Company EPS. If the Interconnecting Customer demonstrates that the Company EPS is adversely affecting the operation of the Facility and if the adverse effect is a result of a Company deviation from Good Utility Practice, the Company shall take appropriate action to eliminate the adverse effect.

6.3. Safe Operations and Maintenance.

Each Party shall operate, maintain, repair, and inspect, and shall be fully responsible for, the facility or facilities that it now or hereafter may own unless otherwise specified in this Agreement. Each Party shall be responsible for the maintenance, repair and condition of its respective lines and appurtenances on their respective side of the PCC. The Company and the Interconnecting Customer shall each provide equipment on its respective side of the PCC that adequately protects the Company's EPS, personnel, and other persons from damage and injury.

6.4. Access.

The Company shall have access to the disconnect switch of the Facility at all times.

6.4 a) Company and Interconnecting Customer Representatives.

STANDARDS FOR INTERCONNECTION OF DISTRIBUTED GENERATION

Each Party shall provide and update as necessary the telephone number that can be used at all times to allow either Party to report an emergency.

6.4 b) Company Right to Access Company-Owned Facilities and Equipment.

If necessary for the purposes of the Interconnection Tariff and in the manner it describes, the Interconnecting Customer shall allow the Company access to the Company's equipment and the Company's facilities located on the Interconnecting Customer's or Customer's premises. To the extent that the Interconnecting Customer does not own all or any part of the property on which the Company is required to locate its equipment or facilities to serve the Interconnecting Customer under the Interconnection Tariff, the Interconnecting Customer shall secure and provide in favor of the Company the necessary rights to obtain access to such equipment or facilities, including easements if the circumstances so require. In addition to any rights and easements required by the Company in accordance with the above provision, the Interconnecting Customer shall obtain an executed Landowner Consent Agreement (Exhibit I) from the Landowner, unless the Company, in its sole discretion, waives this requirement.

6.4 c) Right to Review Information.

The Company shall have the right to review and obtain copies of Interconnecting Customer's operations and maintenance records, logs, or other information such as, unit availability, maintenance outages, circuit breaker operation requiring manual reset, relay targets and unusual events pertaining to Interconnecting Customer's Facility or its interconnection with the Company EPS. This information will be treated as customer-confidential and only used for the purposes of meeting the requirements of Section 4.2.4 in the Interconnection Tariff.

7. Disconnection

7.1. Temporary Disconnection

- 7.1 a) Emergency Conditions. Company shall have the right to immediately and temporarily disconnect the Facility without prior notification in cases where, in the reasonable judgment of Company, continuance of such service to Interconnecting Customer is imminently likely

STANDARDS FOR INTERCONNECTION OF DISTRIBUTED GENERATION

to (i) endanger persons or damage property or (ii) cause a material adverse effect on the integrity or security of, or damage to, Company EPS or to the electric systems of others to which the Company EPS is directly connected. Company shall notify Interconnecting Customer promptly of the emergency condition. Interconnecting Customer shall notify Company promptly when it becomes aware of an emergency condition that affects the Facility that may reasonably be expected to affect the Company EPS. To the extent information is known, the notification shall describe the emergency condition, the extent of the damage or deficiency, or the expected effect on the operation of both Parties' facilities and operations, its anticipated duration and the necessary corrective action.

- 7.1 b) Routine Maintenance, Construction and Repair. Company shall have the right to disconnect the Facility from the Company EPS when necessary for routine maintenance, construction and repairs on the Company EPS. The Company shall provide the Interconnecting Customer with a minimum of seven calendar days planned outage notification consistent with the Company's planned outage notification protocols. If the Interconnecting Customer requests disconnection by the Company at the PCC, the Interconnecting Customer will provide a minimum of seven days notice to the Company. Any additional notification requirements will be specified by mutual agreement in the Interconnection Service Agreement. Company shall make an effort to schedule such curtailment or temporary disconnection with Interconnecting Customer.
- 7.1 c) Forced Outages. During any forced outage, Company shall have the right to suspend interconnection service to effect immediate repairs on the Company EPS; provided, however, Company shall use reasonable efforts to provide the Interconnecting Customer with prior notice. Where circumstances do not permit such prior notice to Interconnecting Customer, Company may interrupt Interconnection Service and disconnect the Facility from the Company EPS without such notice.
- 7.1 d) Non-Emergency Adverse Operating Effects. The Company may disconnect the Facility if the Facility is having an adverse operating effect on the Company EPS or other Customers that is not an emergency, and the Interconnecting Customer fails to correct such adverse operating effect after written notice has been provided and a maximum of 45 days to correct such adverse operating effect has elapsed.
- 7.1 e) Modification of the Facility. Company shall notify Interconnecting Customer if there is evidence of a material modification to the Facility and shall have the right to immediately

STANDARDS FOR INTERCONNECTION OF DISTRIBUTED GENERATION

suspend interconnection service in cases where such material modification has been implemented without prior written authorization from the Company.

- 7.1 f) Re-connection. Any curtailment, reduction or disconnection shall continue only for so long as reasonably necessary. The Interconnecting Customer and the Company shall cooperate with each other to restore the Facility and the Company EPS, respectively, to their normal operating state as soon as reasonably practicable following the cessation or remedy of the event that led to the temporary disconnection.

7.2. Permanent Disconnection.

The Interconnecting Customer has the right to permanently disconnect at any time with 30 days written notice to the Company.

- 7.2 a) The Company may permanently disconnect the Facility upon termination of the Interconnection Service Agreement in accordance with the terms thereof.

8. Metering. Metering of the output from the Facility shall be conducted pursuant to the terms of the Interconnection Tariff.
9. Assignment. Except as provided herein, Interconnecting Customer shall not voluntarily assign its rights or obligations, in whole or in part, under this Agreement without Company's written consent. Any assignment Interconnecting Customer purports to make without Company's written consent shall not be valid. Company shall not unreasonably withhold or delay its consent to Interconnecting Customer's assignment of this Agreement. Notwithstanding the above, Company's consent will not be required for any assignment made by Interconnecting Customer to an Affiliate or as collateral security in connection with a financing transaction. In all events, the Interconnecting Customer will not be relieved of its obligations under this Agreement unless, and until the assignee assumes in writing all obligations of this Agreement and notifies the Company of such assumption.
10. Confidentiality. Company shall maintain confidentiality of all Interconnecting Customer confidential and proprietary information except as otherwise required by applicable laws and regulations, the Interconnection Tariff, or as approved by the Interconnecting Customer in the Simplified or Expedited/Standard Application form or otherwise.

STANDARDS FOR INTERCONNECTION OF DISTRIBUTED GENERATION

11. Insurance Requirements.

11.1. General Liability.

- 11.1 a) In connection with Interconnecting Customer's performance of its duties and obligations under the Interconnection Service Agreement, Interconnecting Customer shall maintain, during the term of the Agreement, general liability insurance with a combined single limit of not less than:
- i) Five million dollars (\$5,000,000) for each occurrence and in the aggregate if the Gross Nameplate Rating of Interconnecting Customer's Facility is greater than five (5) MW.
 - ii) Two million dollars (\$2,000,000) for each occurrence and five million dollars (\$5,000,000) in the aggregate if the Gross Nameplate Rating of Interconnecting Customer's Facility is greater than one (1) MW and less than or equal to five (5) MW;
 - iii) One million dollars (\$1,000,000) for each occurrence and in the aggregate if the Gross Nameplate Rating of Interconnecting Customer's Facility is greater than one hundred (100) kW and less than or equal to one (1) MW;
 - iv) Five hundred thousand dollars (\$500,000) for each occurrence and in the aggregate if the Gross Nameplate Rating of Interconnecting Customer's Facility is greater than ten (10) kW and less than or equal to one hundred (100) kW, except for as provide below in subsection 11.1(b).
- 11.1 b) Pursuant to 220 CMR §18.03(2), no insurance is required for Interconnecting Customers with facilities eligible for Class 1 Net Metering (facilities less than or equal to sixty (60) kW. However, the Company recommends that the Interconnecting Customer obtain adequate insurance to cover potential liabilities.
- 11.1 c) Any combination of General Liability and Umbrella/Excess Liability policy limits can be used to satisfy the limit requirements stated above.
- 11.1 d) The general liability insurance required to be purchased in this Section 11 may be purchased for the direct benefit of the Company and shall respond to third party claims

STANDARDS FOR INTERCONNECTION OF DISTRIBUTED GENERATION

asserted against the Company (hereinafter known as “Owners Protective Liability”). Should this option be chosen, the requirement of Section 11.2(a) will not apply but the Owners Protective Liability policy will be purchased for the direct benefit of the Company and the Company will be designated as the primary and “Named Insured” under the policy.

11.1 e) The insurance hereunder is intended to provide coverage for the Company solely with respect to claims made by third parties against the Company.

11.1 f) In the event the Commonwealth of Massachusetts, or any other governmental subdivision thereof subject to the claims limits of the Massachusetts Tort Claims Act, G.L. c. 258 (hereinafter referred to as the “Governmental Entity”) is the Interconnecting Customer, any insurance maintained by the Governmental Entity shall contain an endorsement that strictly prohibits the applicable insurance company from interposing the claims limits of G.L. c. 258 as a defense in either the adjustment of any claim, or in the defense of any lawsuit directly asserted against the insurer by the Company. Nothing herein is intended to constitute a waiver or indication of an intent to waive the protections of G.L. c. 258 by the Governmental Entity.

11.1 g) Notwithstanding the requirements of section 11.1(a) through (f), insurance for certain Governmental Entity facilities may be provided as set forth in section 11.1(g)(i) and (ii) below. Nothing herein changes the provision in subsection 11.1(a)(iv) that exempts Class I Net Metering facilities (less than or equal to 60 kW) from the requirement to obtain insurance. In addition, nothing shall prevent the Governmental Entity from obtaining insurance consistent with the provisions of subsection 11.1(a) through (f), if it is able and chooses to do so.

- i) For solar photovoltaic (PV) facilities with a Gross Nameplate Rating in excess of 60 kW up to 500 kW, the Governmental Entity is not required to obtain liability insurance. Any liability costs borne by the Company associated with a third-party claim for damages in excess of the claims limit of the Massachusetts Tort Claims Act, M.G.L. c. 258, and market-based premium-related costs, if any, borne by the Company associated with insurance for such third-party claims shall be recovered annually on a reconciling basis in Company rates in a manner that shall be reviewed and approved by the Department.
- ii) For (a) PV facilities with a Gross Nameplate Rating in excess of 500 kW up to 5 MW, (b) wind facilities with a Gross Nameplate Rating in excess of 60 kW up to

STANDARDS FOR INTERCONNECTION OF DISTRIBUTED GENERATION

5 MW, and (c) highly efficient combined heat and power facilities with a Gross Nameplate Rating of in excess of 60 kW up to 5 MW, the Governmental Entity is not required to obtain liability insurance, subject to the requirements of the following paragraph.

The Company shall either self-insure for any risk associated with possible third-party claims for damages in excess of the Massachusetts Tort Claims Act limit, or obtain liability insurance for such third-party claims, and the Company is authorized to charge and collect from the Governmental Entity its pro-rata allocable share of the cost of so doing, plus all reasonable administrative costs. The coverage and cost may vary with the size and type of facility, and may change (increase or decrease) over time, based on insurance market conditions, and such cost shall be added to, and paid for as part of the Governmental Entity's electric bill.

11.2. Insurer Requirements and Endorsements.

All required insurance shall be carried by reputable insurers qualified to underwrite insurance in MA having a Best Rating of at least "A-". In addition, all insurance shall, (a) include Company as an additional insured; (b) contain a severability of interest clause or cross-liability clause; (c) provide that Company shall not incur liability to the insurance carrier for payment of premium for such insurance; and (d) provide for thirty (30) calendar days' written notice to Company prior to cancellation, termination, or material change of such insurance; provided that to the extent the Interconnecting Customer is satisfying the requirements of subpart (d) of this paragraph by means of a presently existing insurance policy, the Interconnecting Customer shall only be required to make good faith efforts to satisfy that requirement and will assume the responsibility for notifying the Company as required above.

If the requirement of clause (a) in the paragraph above prevents Interconnecting Customer from obtaining the insurance required without added cost or due to written refusal by the insurance carrier, then upon Interconnecting Customer's written Notice to Company, the requirements of clause (a) shall be waived.

11.3. Evidence of Insurance.

STANDARDS FOR INTERCONNECTION OF DISTRIBUTED GENERATION

Evidence of the insurance required shall state that coverage provided is primary and is not in excess to or contributing with any insurance or self-insurance maintained by Interconnecting Customer.

The Interconnecting Customer is responsible for providing the Company with evidence of insurance in compliance with the Interconnection Tariff on an annual basis.

Prior to the Company commencing work on System Modifications, and annually thereafter, the Interconnecting Customer shall have its insurer furnish to the Company certificates of insurance evidencing the insurance coverage required above. The Interconnecting Customer shall notify and send to the Company a certificate of insurance for any policy written on a "claims-made" basis. The Interconnecting Customer will maintain extended reporting coverage for three years on all policies written on a "claims-made" basis.

In the event that an Owners Protective Liability policy is provided, the original policy shall be provided to the Company.

11.4. Self Insurance.

If Interconnecting Customer has a self-insurance program established in accordance with commercially acceptable risk management practices. Interconnecting Customer may comply with the following in lieu of the above requirements as reasonably approved by the Company:

- Interconnecting Customer shall provide to Company, at least thirty (30) calendar days prior to the Date of Initial Operation, evidence of such program to self-insure to a level of coverage equivalent to that required.
- If Interconnecting Customer ceases to self-insure to the standards required hereunder, or if Interconnecting Customer is unable to provide continuing evidence of Interconnecting Customer's financial ability to self-insure, Interconnecting Customer agrees to promptly obtain the coverage required under Section 11.1.

This section shall not allow any Governmental Entity to self-insure where the existence of a limitation on damages payable by a Government Entity imposed by the Massachusetts

STANDARDS FOR INTERCONNECTION OF DISTRIBUTED GENERATION

Tort Claims Act, G.L. c. 258, or similar law, could effectively limit recovery (by virtue of a cap on recovery) to an amount lower than that required in Section 11.1(a).

- 11.5. All insurance certificates, statements of self-insurance, endorsements, cancellations, terminations, alterations, and material changes of such insurance shall be issued and submitted to the following:

Eversource

Attention: **DG Group, SW 340**

Phone: **508-790-9035**

DG Senior Account Executive

Melanie.Khederian@eversource.com

12. Indemnification. Except as the Commonwealth is precluded from pledging credit by Section 1 of Article 62 of the Amendments to the Constitution of the Commonwealth of Massachusetts, and except as the Commonwealth's cities and towns are precluded by Section 7 of Article 2 of the Amendments to the Massachusetts Constitution from pledging their credit without prior legislative authority, Interconnecting Customer and Company shall each indemnify, defend and hold the other, its directors, officers, employees and agents (including, but not limited to, Affiliates and contractors and their employees), harmless from and against all liabilities, damages, losses, penalties, claims, demands, suits and proceedings of any nature whatsoever for personal injury (including death) or property damages to unaffiliated third parties that arise out of or are in any manner connected with the performance of this Agreement by that Party except to the extent that such injury or damages to unaffiliated third parties may be attributable to the negligence or willful misconduct of the Party seeking indemnification.
13. Limitation of Liability. Each Party's liability to the other Party for any loss, cost, claim, injury, liability, or expense, including court costs and reasonable attorney's fees, relating to or arising from any act or omission in its performance of this Agreement, shall be limited to the amount of direct damage or liability actually incurred. In no event shall either Party be liable to the other Party for any indirect, incidental, special, consequential, or punitive damages of any kind whatsoever.
14. Amendments and Modifications. No amendment or modification of this Agreement shall be binding unless in writing and duly executed by both Parties.
15. Permits and Approvals. Interconnecting Customer shall obtain all environmental and other permits lawfully required by governmental authorities for the construction and operation of the Facility. Prior

STANDARDS FOR INTERCONNECTION OF DISTRIBUTED GENERATION

to the construction of System Modifications the Interconnecting Customer will notify the Company that it has initiated the permitting process. Prior to the commercial operation of the Facility the Interconnecting Customer will notify the Company that it has obtained all permits necessary. Upon request the Interconnecting Customer shall provide copies of one or more of the necessary permits to the Company.

16. Force Majeure. For purposes of this Agreement, “Force Majeure Event” means any event:
- a) that is beyond the reasonable control of the affected Party; and
 - b) that the affected Party is unable to prevent or provide against by exercising commercially reasonable efforts, including the following events or circumstances, but only to the extent they satisfy the preceding requirements: acts of war or terrorism, public disorder, insurrection, or rebellion; floods, hurricanes, earthquakes, lightning, storms, and other natural calamities; explosions or fire; strikes, work stoppages, or labor disputes; embargoes; and sabotage. If a Force Majeure Event prevents a Party from fulfilling any obligations under this Agreement, such Party will promptly notify the other Party in writing, and will keep the other Party informed on a continuing basis of the scope and duration of the Force Majeure Event. The affected Party will specify in reasonable detail the circumstances of the Force Majeure Event, its expected duration, and the steps that the affected Party is taking to mitigate the effects of the event on its performance. The affected Party will be entitled to suspend or modify its performance of obligations under this Agreement, other than the obligation to make payments then due or becoming due under this Agreement, but only to the extent that the effect of the Force Majeure Event cannot be mitigated by the use of reasonable efforts. The affected Party will use reasonable efforts to resume its performance as soon as possible. In no event will the unavailability or inability to obtain funds constitute a Force Majeure Event.

STANDARDS FOR INTERCONNECTION OF DISTRIBUTED GENERATION

17. Notices.

17.1. Any written notice, demand, or request required or authorized in connection with this Agreement (“Notice”) shall be deemed properly given on the date actually delivered in person or five (5) Business Days after being sent by certified mail, e-mail or fax with confirmation of receipt to the person specified below:

If to Company:	Name Eversource Attention: DG Group, SW340 Phone: 508-790-9035 Email: Melanie.khederian@eversource.com
----------------	---

If to Interconnecting Customer:	Name: BE RE, LLC Attention: Adam Schumaker Address: 50 W. Broadway, #700 City: Salt Lake City, Utah 84109 Phone: 385-315-0024 Email: aschumaker@nextsunenergy.com
---------------------------------	--

17.2. A Party may change its address for Notices at any time by providing the other Party Notice of the change in accordance with Section 17.1.

17.3. The Parties may also designate operating representatives to conduct the daily communications, which may be necessary or convenient for the administration of this Agreement. Such designations, including names, addresses, email addresses, and phone numbers may be communicated or revised by one Party’s Notice to the other.

18. Default and Remedies.

18.1. Defaults. Any one of the following shall constitute “An Event of Default.”

STANDARDS FOR INTERCONNECTION OF DISTRIBUTED GENERATION

- i) One of the Parties shall fail to pay any undisputed bill for charges incurred under this Agreement or other amounts which one Party owes the other Party as and when due, and such failure shall continue for a period of thirty (30) days after written notice of nonpayment from the affected Party to the defaulting Party, or
- ii) One of the Parties fails to comply with any other provision of this Agreement or breaches any representation or warranty in any material respect and fails to cure or remedy that default or breach within sixty (60) days after notice and written demand by the affected Party to cure the same or such longer period reasonably required to cure (not to exceed an additional 90 days unless otherwise mutually agreed upon), provided that the defaulting Party diligently continues to cure until such failure is fully cured.

18.2. Remedies. Upon the occurrence of an Event of Default, the affected Party may at its option, in addition to any remedies available under any other provision herein, do any, or any combination, as appropriate, of the following:

- a) Continue to perform and enforce this Agreement;
- b) Recover damages from the defaulting Party except as limited by this Agreement;
- c) By written notice to the defaulting Party terminate this Agreement;
- d) Pursue any other remedies it may have under this Agreement or under applicable law or in equity.

19. Entire Agreement. This Agreement, including any attachments or appendices, is entered into pursuant to the Interconnection Tariff. Together the Agreement and the Interconnection Tariff represent the entire understanding between the Parties, their agents, and employees as to the subject matter of this Agreement. Each Party also represents that in entering into this Agreement, it has not relied on any promise, inducement, representation, warranty, agreement or other statement not set forth in this Agreement or in the Company's Interconnection Tariff.

20. Supersedence. In the event of a conflict between this Agreement, the Interconnection Tariff, or the terms of any other tariff, Exhibit or Attachment incorporated by reference, the terms of the Interconnection Tariff, as the same may be amended from time to time, shall control. In the event that

STANDARDS FOR INTERCONNECTION OF DISTRIBUTED GENERATION

the Company files a revised tariff related to interconnection for Department approval after the effective date of this Agreement, the Company shall, not later than the date of such filing, notify the signatories of this Agreement and provide them a copy of said filing.

21. **Governing Law.** This Agreement shall be interpreted, governed, and construed under the laws of the Commonwealth of Massachusetts without giving effect to choice of law provisions that might apply to the law of a different jurisdiction.
22. **Non-waiver.** None of the provisions of this Agreement shall be considered waived by a Party unless such waiver is given in writing. The failure of a Party to insist in any one or more instances upon strict performance of any of the provisions of this Agreement or to take advantage of any of its rights hereunder shall not be construed as a waiver of any such provisions or the relinquishment of any such rights for the future, but the same shall continue and remain in full force and effect.
23. **Counterparts.** This Agreement may be signed in counterparts.
24. **No Third Party Beneficiaries.** This Agreement is made solely for the benefit of the Parties hereto.
Nothing in the Agreement shall be construed to create any rights in or duty to, or standard of care with respect to, or any liability to, any person not a party to this Agreement.
25. **Dispute Resolution.** Unless otherwise agreed by the Parties, all disputes arising under this Agreement shall be resolved pursuant to the Dispute Resolution Process set forth in the Interconnection Tariff.
26. **Severability.** If any clause, provision, or section of this Agreement is ruled invalid by any court of competent jurisdiction, the invalidity of such clause, provision, or section, shall not affect any of the remaining provisions herein.
27. **Signatures.**

IN WITNESS WHEREOF, the Parties hereto have caused two (2) originals of this Agreement to be executed under seal by their duly authorized representatives.

STANDARDS FOR INTERCONNECTION OF DISTRIBUTED GENERATION

Interconnecting Customer

Company

By:  _____

By: _____

Name: Adam Schumaker _____

Name: _____

Title: Manager _____

Title: _____

Date: December 14, 2018 _____

Date: _____

STANDARDS FOR INTERCONNECTION OF DISTRIBUTED GENERATION

The following attachments will be included as appropriate for each specific Interconnection Service Agreement:

Attachment 1: Description of Facilities, including demarcation of Point of Common Coupling

Attachment 2: Description of System Modifications

Attachment 3: Costs of System Modifications and Payment Terms

Attachment 4: Special Operating Requirements, if any

Attachment 1

Description of facility and Point of Common Coupling (One Line)

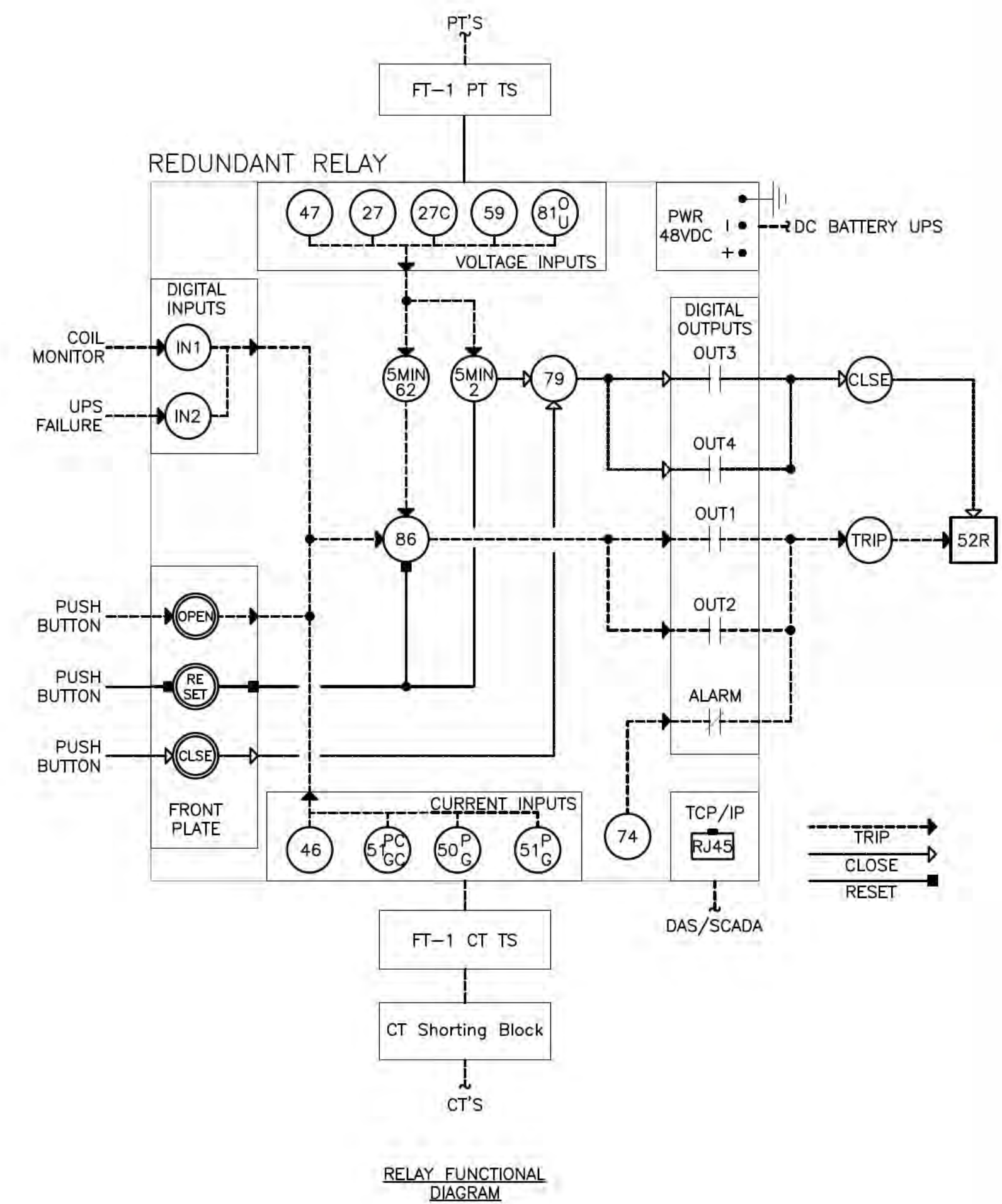
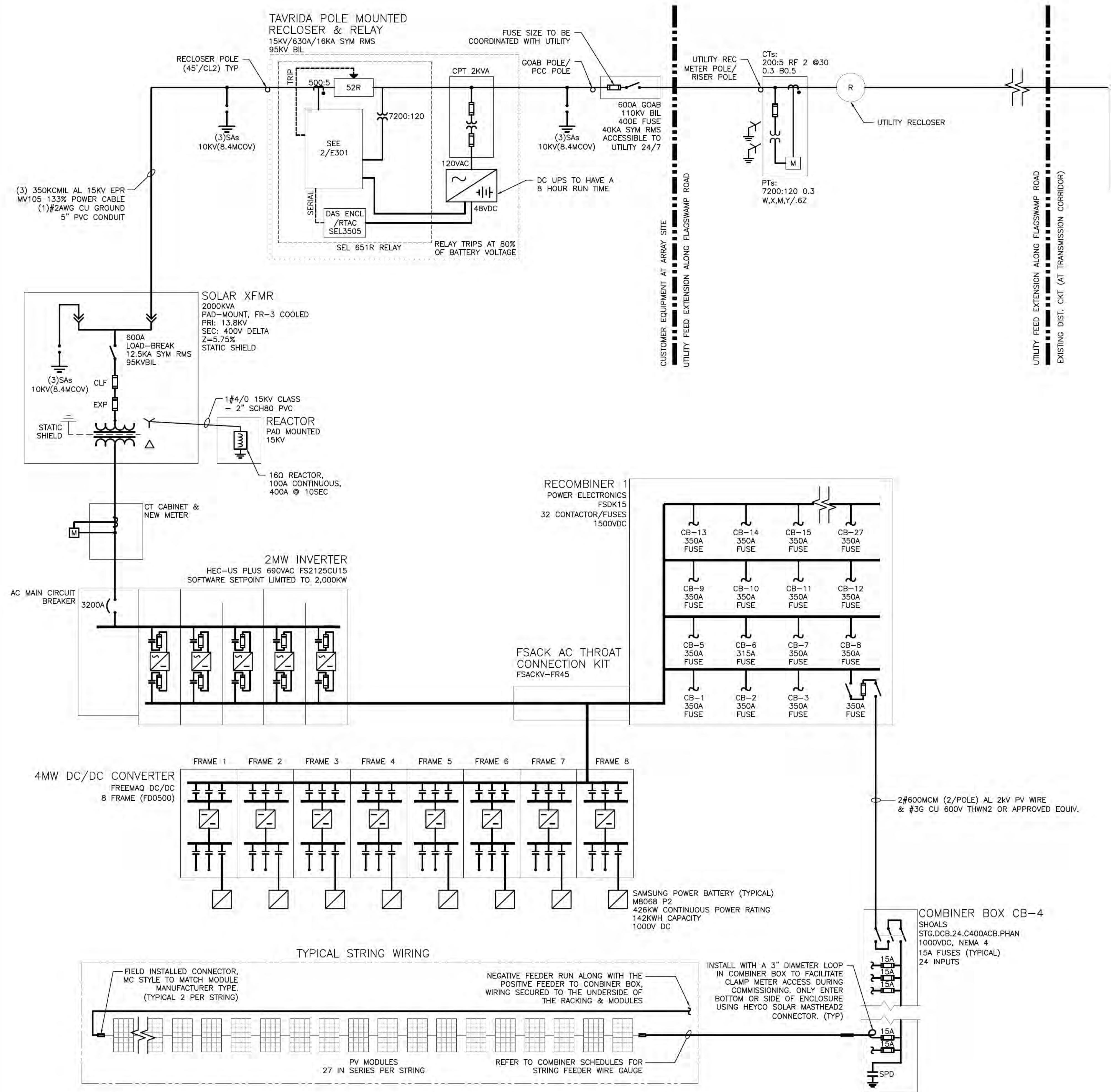

SEL-651R						
ANSI ELEMENT #	Pickup	Real	Level	Delay (sec)	Curve	Description
27	111.9V	6714.4V	88.0%	1.95		Slow UV
27	63.58V	3815V	50.0%	1.05		Fast UV
27	57.22V	3433.5V	45.0%	0.11		Instantaneous UV
27C	101.73V	6104V	80.0%			Voltage Controlled UV
59	139.88V	8393V	110.0%	2.05		Slow OV
59	152.6V	9156V	120.0%	0.11		Fast OV
59	158.95V	9537.5V	125.0%	0.05		Instantaneous OV
59N	16.53V	991.9V	13.0%	1.95		Neutral Shift
47		10.0%	10.0%	9.95		voltage unbalance
81U-1	56.58	56.5Hz	94.3%	0.11		Fast UF
81U-2	58.50	58.5Hz	97.5%	299.95		Slow UF
81O-1	62.04	62Hz	103.4%	0.11		Fast OF
81O-2	60.60	60.6Hz	101.0%	299.95		Slow OF
51	4.37A	437A	200.0%	1.95	C3	Time Phase OC
50	26.22A	2622.1A	1200.0%	0.02		Instantaneous P OC
51C	0.43A	43.7A	20.0%	1.95	U4	Timed VC Overcurrent
51CG	0.43A	43.7A	20.0%	1.45	U4	Timed VC Ground Overcurrent
51G	0.54A	54.6A	25.0%	1.95	C3	Timed Ground OC
46		25% at Solar Power Levels above 1247.5KW		9.95		current unbalance
79				299.95		delay to close after 27,59,81 clear
32				0.95		directional power

*Total Clear Time = 3 cycle breaker opening time + delay

218.51A USED FOR 50/51 ELEMENTS 7630V USED FOR 27/59 ELEMENTS

CT RATIO FACTOR = 100 PT RATIO FACTOR = 60

Attachment 2

Description of System Modifications

The interconnection of this distributed generation application is queued behind other applicants which may require system upgrades to the Eversource system, and the cost for those upgrades has been included as a requirement in their respective Interconnection Services Agreement(s).

If a prior applicant should dequeue or withdraw for any reason, the system conditions permitting the interconnection of succeeding applicant(s) may change. Upon the withdrawal of previously queued applicants, succeeding applicant(s) may become responsible some or all of the system upgrades that were required for the prior applicants, and Eversource may have to reassess system conditions to determine if the applicant currently under study would trigger the same upgrades

All metering must comply with Eversource Bluebook Standards - see link - specifically regarding hot sequence and cold sequence

[Bluebook Standards](#)

The following upgrades are currently required for this DG Interconnection Application:

Scope

25% Distribution Upgrades - ██████████

This estimate includes a 13.2kV lateral tap with a recloser off of circuit 2-541-541 in the vicinity of P#9010/37 at the intersection of Flag Swamp Rd and ROW #144.

Extending this new tap using 13.2kV, 3-phase 477 ACSS for approximately 2,100' to the vicinity of P#158/26 at the entrance to the DG site near 203 Flag Swamp Rd, a recloser, primary meter and primary disconnects at the PCC.

ISO may require additional studies that could impact timing and cost of the project

The distribution impact study indicates failed SANDIA islanding screens and either a dynamic Risk of Islanding study must be conducted, or Eversource must install reclose blocking for your project. The dynamic risk of islanding study still needs to be performed for this project before it can interconnect. The cost of installation of reclose blocking has not been included in the +/- 25% cost estimate that was provided to you

Cost of System Modifications and Payment Terms

The **Eversource** cost summary is shown below:

Project Cost / Fees: Project Work Order Number **2273508**

The enclosed total cost of [REDACTED] **(+/- 25%)** regarding Project Work Order Number **2273508**, must all be paid in full to move the project forward into construction.

Eversource's and the Applicant will mutually agree upon a construction schedule which will take be required to consider inclement weather and customer outages for completion. This will be established upon the **Eversource** construction final design. Note: For customers with multiple projects, **Eversource** will require a priority listing of those projects and timeframe for completion to sufficiently order materials and to determine the projected construction schedule.

The following check off items will be required, prior to commencement of system modifications and construction:

- Payment in full prior to beginning of any construction work by **Eversource**
- Approved final electrical wiring inspection
- Approved final customer relay/protection settings
- Signed easement and/or rights documents, if applicable
- Verizon (pole set) areas or towns must be completed prior to **Eversource** modifications
- Signed agreements to operate within **Eversource** Right-of-Ways, if applicable
- Other documents as required

Your Witness Test for Final Commissioning can then take place once you have completed the check-off steps as part of the Interconnection Agreement and that the solar array is connected (energized) to Eversource's distribution system.

Please mail your payment, made payable to **Eversource** as shown below. Please reference the **Eversource** Electric Work Order **#2273508** on the check. This cost is valid for Ninety (90) calendar days from the date of this letter. Note: the customer is responsible for all costs on private property.

Upon the 1st payment Eversource will then schedule the final engineering and design to be completed. This may take up to 2 – 3 months for review and approval based on the complexity of the Work Order.

Eversource

ATTN: DG Group, WO# 2273508

247 Station Dr, SW340

Westwood, MA 02090-9230

Attachment 4
Special Operating Requirements

General Clause:

The Customer acknowledges and agrees to certain operating constraints required by the Company so that its Facility does not adversely affect the Company's electric power system or the quality of power delivered by it.

General Off-unity power factor operation (for facilities of 500kW or greater):

The Customer's Facility must be capable of operating at power factors within +/-0.95, and the Customer must adjust the Facility's control parameters to output at power factors within that range at the request of the Company in order to mitigate voltage deviations or other power quality phenomenon on the circuits that interconnect the Facility. Any such requests will be issued to the Customer in writing. The Company may consult with the Customer in order to determine a control methodology that will provide adequate mitigation that is consistent with the control capabilities of the Facility and are of least impact to the Customer; however, the requirements will ultimately be determined at the sole discretion of the Company. Should the Company determine that the Customer is operating its Facility contrary to this requirement; the Company will disconnect the Facility and will not allow re-connection until the Company is satisfied that the customer has implemented appropriate changes to its controls and/or settings to achieve the required performance.

Inverters must have adjustable power factor. The Company has the right to go back and request off unity output from the DG interconnection.

This facility will be tripped offline via an Eversource recloser when the normal electrical Feed is not in operation. This includes when the area is fed from another feeder which is not the normal electrical feed. The facility will not be allowed on-line until the normal electrical feed is restored to service.